

# 120 AGC series

## 120X120X25mm

### ●General Specification / 一般規格

- Motor / DC brushless motor
- Material / Frame : plastic(94V-0)  
Impeller : plastic(94V-0)
- Bearing / Ball bearing
- Weight / 230g
- 馬達 / 直流單向無刷馬達
- 材質 / 框：塑膠(94V-0)  
葉：塑膠(94V-0)
- 軸承 / 滾珠軸承
- 重量 / 230克



### ●Specification / 詳細規格 \* 軸承/bearing B: 雙滾珠/ball bearing F:FMB S: 含油承軸/sleeve bearing

Model	Bearing	Voltage	Operating Vol.	Current	Speed	Max. Air Flow		Max. Static Pressure		Sound	Weight
機型	軸承	電壓	操作電壓	電流	轉速	最大風量		最大風壓		噪音	重量
P/N	B/S/F	V	V	A	RPM	m <sup>3</sup> /min	CFM	mm-H <sub>2</sub> O	In-H <sub>2</sub> O	dBA	g
AGC12025*12J	B	12	6.0~13.2	0.22	2100	1.91	67.27	4.07	0.16	32.60	230
AGC12025*12L	B	12	6.0~13.2	0.24	2500	2.33	82.17	5.65	0.22	35.60	230
AGC12025*12M	B	12	6.0~13.2	0.33	2800	2.58	91.05	6.82	0.27	39.21	230
AGC12025*12H	B	12	6.0~13.2	0.50	3400	3.13	110.48	9.56	0.38	44.47	230
AGC12025*12U	B	12	6.0~13.2	0.66	3700	3.43	121.28	11.14	0.44	47.38	230
AGC12025*12V	B	12	6.0~13.2	0.76	4000	3.70	130.63	13.06	0.51	49.21	230
AGC12025*24J	B	24	12.0~26.4	0.09	2100	1.91	67.27	4.07	0.16	32.60	230
AGC12025*24L	B	24	12.0~26.4	0.12	2500	2.33	82.17	5.65	0.22	35.60	230
AGC12025*24M	B	24	12.0~26.4	0.14	2800	2.58	91.05	6.82	0.27	39.21	230
AGC12025*24H	B	24	12.0~26.4	0.22	3400	3.13	110.48	9.56	0.38	44.47	230
AGC12025*24U	B	24	12.0~26.4	0.32	3700	3.43	121.28	11.14	0.44	47.38	230
AGC12025*24V	B	24	12.0~26.4	0.39	4000	3.70	130.63	13.06	0.51	49.21	230
AGC12025*48L	B	48	24.0~52.8	0.08	2500	2.33	82.17	5.65	0.22	35.60	230
AGC12025*48M	B	48	24.0~52.8	0.09	2800	2.58	91.05	6.82	0.27	39.21	230
AGC12025*48H	B	48	24.0~52.8	0.20	3400	3.13	110.48	9.56	0.38	44.47	230

### ● Drawing & panel out-cuts/ 圖面及出入風口

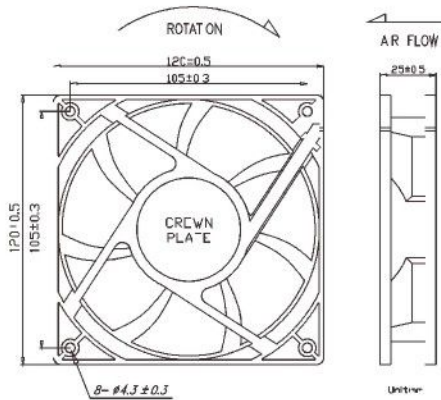

### ● Characteristic Curves/ 特性曲線

